

WHITE PAPER

Dispersion Trimming using the Programmable Group Delay capability of the WaveShaper Family of Programmable Optical Processors

Abstract

The ever increasing bit-rates of optical communications networks are placing growing demands on network optimization and in particular on dispersion management. The WaveShaper family of Programmable Optical Processors, provides an ideal workbench for evaluating tuneable dispersion trimming for 40 and 100 GBit/s systems.

The WaveShaper is based on Liquid Crystal on Silicon (LCoS) Technology [1,2] which uses a two-dimensional array of phase modulating pixels as shown in Figure 1. The optical signal overlaps a large number of pixels (typically 400) in one dimension ("vertical"), whilst in the other dimension ("horizontal"), the spectrum is spatially dispersed, so that wavelengths can be processed individually.

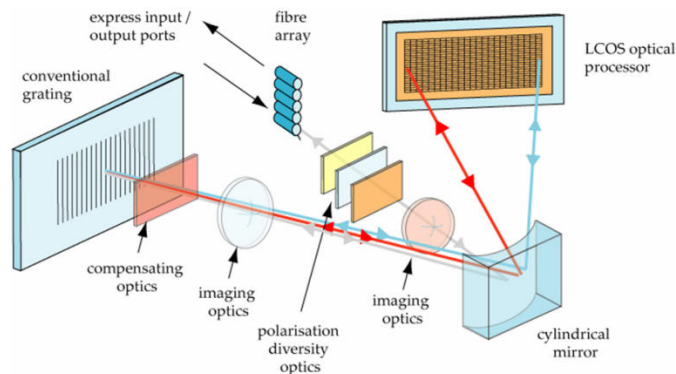

Figure 1: Simplified schematic layout of the WaveShaper 4000S.

Specially calculated phase front images (modulo 2π) are then applied to this spatially dispersed signal via the LCoS which modulates the phase front of the signal through the voltage dependent retardation of each pixel.

The control of optical signal power, together with the switching functionality is obtained by varying the vertical phase curve, and can be set independently for each wavelength. In this White Paper we discuss how the phase

of the image on the LCoS can be varied along the spectral axis to modulate the group delay across the spectrum, which results in a dispersion generating or compensating device.

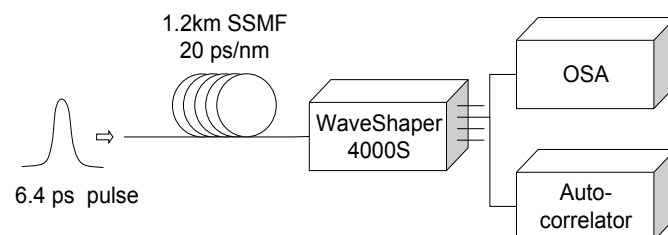

Figure 2: Experimental setup for proof of principle demonstration

1. Spectral phase modulation using Channel Contouring technology

The WaveShaper is based on Liquid Crystal on Silicon (LCoS) Technology [1,2] which uses a two-dimensional array of phase modulating pixels as shown in Figure 1. The optical signal overlaps a large number of pixels (typically 400) in one dimension ("vertical"), whilst in the other dimension ("horizontal"), the spectrum is spatially dispersed, so that wavelengths can be processed individually.

Specially calculated phase front images (modulo 2π) are then applied to this spatially dispersed signal via the LCoS which modulates the phase front of the signal through the voltage dependent retardation of each pixel.

The control of optical signal power, together with the switching functionality is obtained by varying the vertical phase curve, and can be set independently for each wavelength. In this White Paper we discuss how the phase of the image on the LCoS can be varied along the spectral axis to modulate the group delay across the spectrum, which results in a dispersion generating or compensating device.

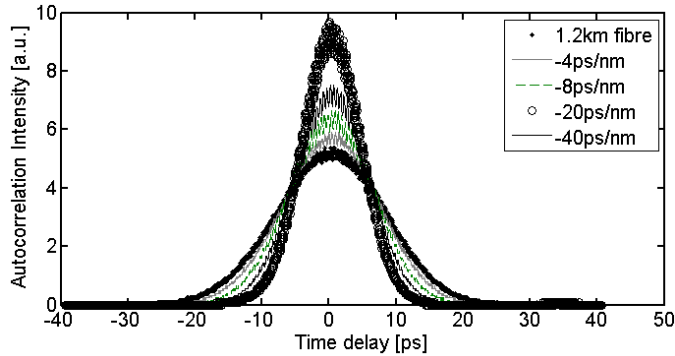

Figure 3: Autocorrelation traces of pulses after propagation over 1.2km of SMF and respective compensation by the WaveShaper with settings of -4, -8, -20 and -40 ps/nm.

In the WaveShaper, each wavelength is manipulated by a specific vertical column on the LCoS. Therefore, by varying the relative phase between adjacent LCoS columns, it is possible to directly control the spectral phase of the light reflected to the determined output port(s), which in turn directly relate to effects in the time domain due to the Fourier relationship between the two domains. For example, a linear phase ramp in the spectral domain corresponds to an offset in the time domain whilst a parabolic spectral phase corresponds to a linear group delay. This property can be used to compensate or generate dispersion over a certain wavelength range. Of particular interest is the ability to set the phase modulation independently for any chosen channel. This capability, termed Channel Contouring allows for arbitrary compensation of dispersion in any wavelength channel, since each channel can be “contoured” individually.

2. Compensation for dispersion in Standard Single Mode Fiber

As a proof of principle demonstration a WaveShaper 4000S was configured to compensate the dispersion imposed on a short pulse by 1.2 km of single mode fiber. Figure 2 shows how short pulses (6.4 ps long, 10 GHz repetition rate) were sent through 1.2 km of standard single mode fiber (ITU-T G.654, resulting in a total dispersion of 20 ps/nm). The WaveShaper was programmed using User Configured Filters to generate 0, -4, -8, -20 and -40 ps/nm dispersion respectively.

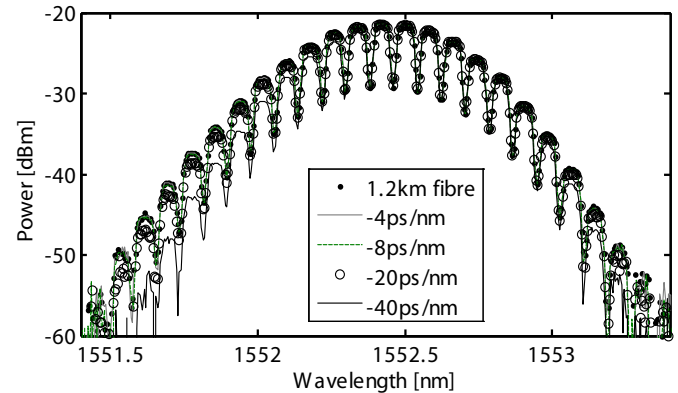

Figure 4: Spectra of the pulses after compensation by a WaveShaper 4000S.

For each of the different dispersion settings, the output pulses are measured with an optical autocorrelator and an optical spectrum analyzer. The results are shown in Figures 3 and 4 respectively. As can be seen, the pulses are optimally recompressed when a dispersion of -20 ps/nm is applied, compensating the dispersion acquired through propagation in the fiber. Higher values of the dispersion in the WaveShaper cause the pulse to lengthen again due to over-compensation. The wavelength dependent loss, as a parasitic effect of the parabolic phase modulation, is insignificant for dispersion values of up to at least ± 40 ps/nm. Depending on which bandwidth the dispersion needs to be compensated for, the dispersion can be further increased. The band narrowing effect is expressed conveniently by the dispersion-bandwidth product of the WaveShaper, which is 40 ps. This means that dispersions of up to ± 40 ps/nm can comfortably be generated over an optical bandwidth of 1 nm. Reducing the channel bandwidth requirement to 0.5 nm increases the total obtainable dispersion to ± 80 ps/nm. Note that in the WaveShaper 4000S, the dispersion-bandwidth product is approximately twice that in the 4000S, allowing dispersion of up to ± 80 ps/nm to be compensated over a 1nm filter bandwidth.

The parasitic Gaussian shaping of the channels that accompanies dispersion can be mitigated by attenuating the central wavelengths of the channel accordingly.

3. High speed transmission experiments

As a demonstration of how the group delay control of the WaveShaper can improve the performance of 40 Gbit/s transmission system, a WaveShaper 4000S was used in an emulation of an agile network, as shown in Figure 5.

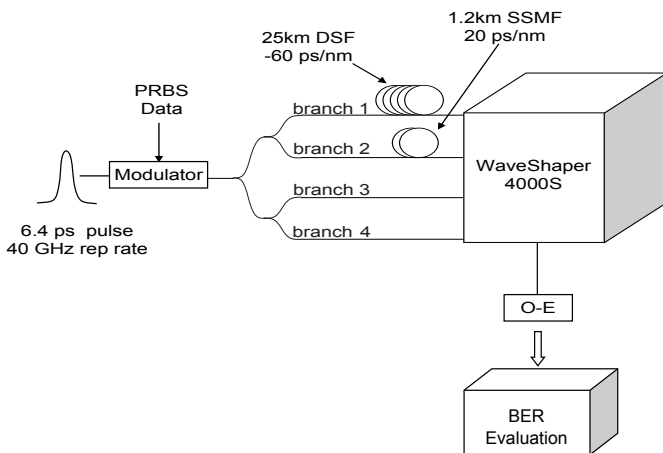

Figure 5: Emulation of an agile network with the WaveShaper 4000S.

Here, a 40 GHz pulse train of pulses, again 6.4 ps long, are data modulated with a pseudo-random bit sequence of data. A 1x4 coupler then splits the pulses to 4 separate branches of the network, two of which contain different stretches of fiber. The four branches of the network are connected to the four switch ports of the WaveShaper 4000S. The WaveShaper software allows the user to both select which branch to switch to the output port and secondly tailor the dispersion of the filter so that it perfectly compensates the dispersion that the optical signal has acquired.

Figure 6 shows a series of eye diagrams, measured with a high speed electrical sampling oscilloscope, after O-E conversion with a high speed photodiode. After propagating in branch 1, with a total dispersion $D = -60$ ps/nm, the eye diagram is almost completely closed. The WaveShaper 4000S is able to fully reopen the eye using a dispersion of 60 ps/nm. Similarly after branch 2, the pulses are dispersed by 20 ps/nm. The original pulses are restored by a matched dispersion setting of the WaveShaper.

Due to electronic ringing effects, the eye diagram becomes slightly worse when the received pulses are at their shortest (i.e. 6.4 ps). This explains the negative power penalty for the situations where the WaveShaper 4000S is over- or under-compensating the dispersion by about 20 ps/nm. The pulses

then become slightly longer, and the ringing reduces. This can also be seen in the respective eye diagrams

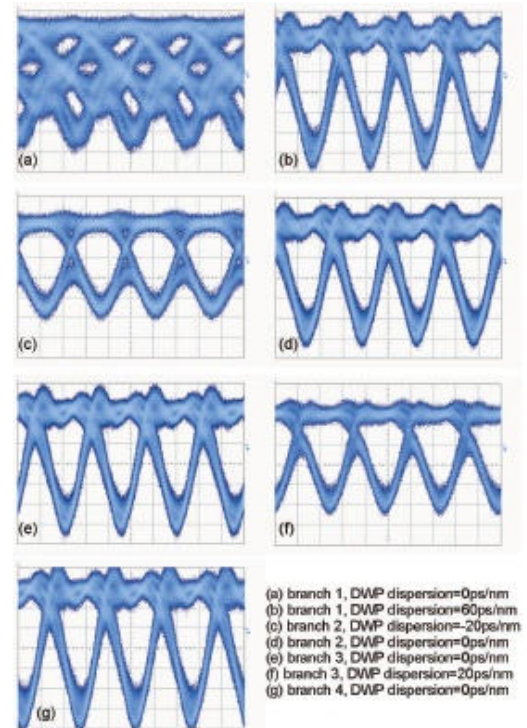

Figure 6: Eye diagrams for different scenarios on the agile network. The scales are identical for all plots: 10 ps/div on the horizontal axis and 50 mV/div on the vertical axis

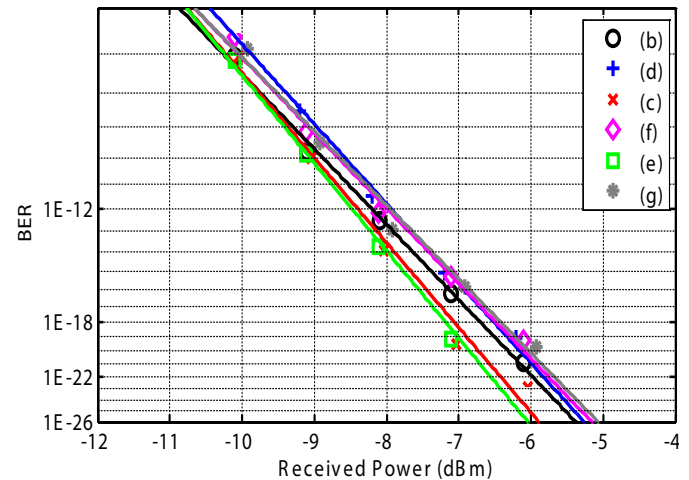

Figure 7: Best obtainable Bit Error Rate (BER) versus received power for various scenarios (see Figure 6).

Even though the spectral narrowing is starting to become significant for dispersion values of around 60 ps/nm, as can be seen in Figure 7, the power penalty after dispersion compensation with the WaveShaper is virtually 0, for situation 6b. In this case, the dispersion setting can be

WHITE PAPER: Dispersion Trimming using the Programmable Group Delay capability of the WaveShaper Family of Programmable Optical Processors

reduced by about 20 ps/nm to reduce the ringing, and further improve the bit error rate. Although not shown here, the dispersion can be tailored for each wavelength channel separately, and can be combined with arbitrary attenuation levels, for example for channel equalization purposes. This was demonstrated for channel bit-rates of 80 Gbit/s, for 4 different wavelengths [3].

4. Summary

The WaveShaper family provides unique capabilities in switching and control of the group delay within a DWDM channel. Full access to the spectral phase of each channel gives unprecedented control over the optical signals for high-speed system development and pulse manipulation.

5. Acknowledgement

This work described in this White Paper was carried out by the Centre for Ultrahigh Devices for Optical Systems

(CUDOS) at the University of Sydney as part of an ARC Linkage Project Grant with Finisar Australia.

6. References

- [1] G. Baxter et al., "Highly programmable Wavelength Selective Switch based on Liquid Crystal on Silicon switching elements" in Proc. OFC/NFOEC 2006, OTuF2 (2006).
- [2] S. Frisken et al., "High performance 'Drop and Continue' functionality in a wavelength selective switch" in Proc. OFC/NFOEC 2006, PDP14 (2006).
- [3] M.A.F. Roelens et al., "Tunable Dispersion Trimming in Dynamic Wavelength Processor at 80 Gbit/s per channel", in Proc. OFC/NFOEC 2007, PDP44 (2007).

Finisar[®]

1389 Moffett Park Drive
Sunnyvale, CA 94089

Tel.: +1-408-548-1000

Fax: +1-408-541-6138

waveshaper@finisar.com

<http://www.finisar.com/optical-instrumentation>

©2012 Finisar Corporation. All rights reserved.
Finisar is a registered trademark. WSPR 03/12